

EZ-TUBE



DOWNLOAD FULL SPECS
& INSTRUCTIONS AT

EZ-CRETE.COM

Actual EZ-Tube

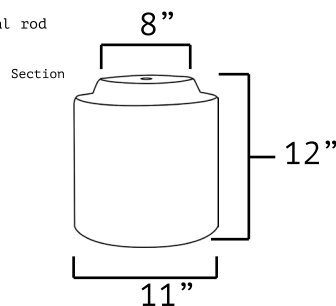
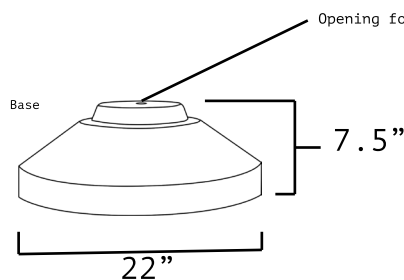
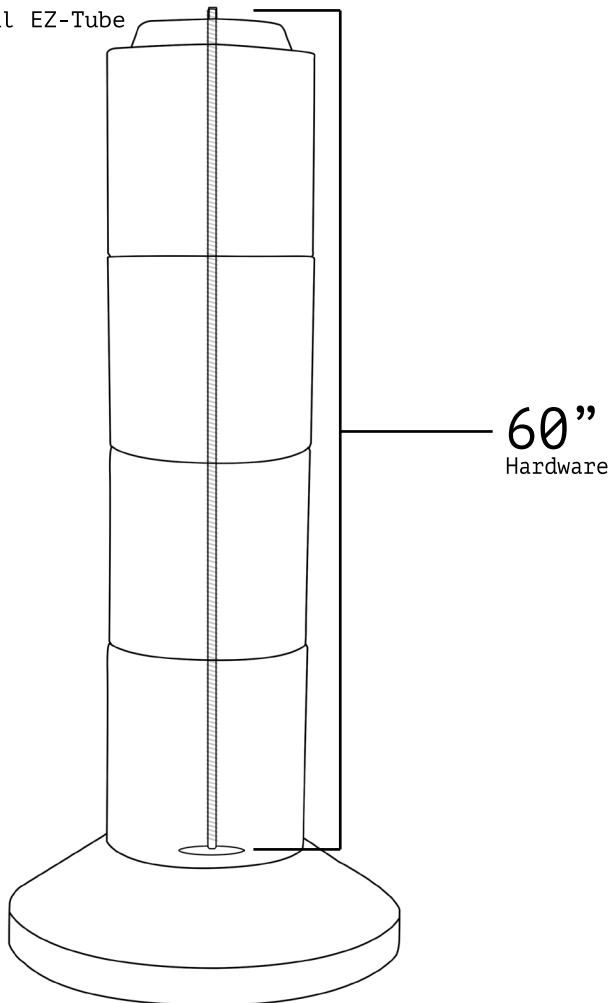

SPECS:

- Upper Section Weight: 60 lbs. typ.
- Base Section Weight: 100 lbs. typ.
- Height: Approx. 50"
- Base: 22" Diameter
- Top: Accommodates up to 6" x 6" post
- Load Rating: 135,000 lbs. at top.
- 60" x 3/8" galv. anchor rod with base plate (cut to length on site)

INSTALLATION:

Dig hole or trench to the required depth (below frost line).

Prep bottom with crushed stone as necessary.

Thread anchor rod through base section.

Place base and anchor into position.

Add upper sections by sliding over anchor rod, adding blow grade rated caulking between each layer.

Level, plumb & align as necessary.

Backfill, compacting soil every six inches.

Keep building.



UNIVERSITY of NEW HAMPSHIRE
June 14, 2010

Mr. Brice Raynor
EZ Crete LLC
Re: Testing of the EZ Tube system

Dear Mr. Raynor

Please be advised the testing of your EZ Tube concrete system has been completed. Ten EZ Tube components were delivered by EZ Concrete LLC to the Structural High bay testing facility of the Department of Civil Engineering at the University of New Hampshire in Durham New Hampshire. These EZ components consisted of two base sections, seven upper sections and one loading head as listed in Table 1.

PRODUCT DESCRIPTION

The EZ Tube concrete system consists of a unique system designed to simplify the construction of a concrete foundation. The 20" diameter base section supports the 12" diameter 12" high upper sections as shown in Figure 1. The center of both sections has a 5/8" hole for the placement of a steel rod designed to hold a connection plate on the top of the last upper section to attach timber components for ease of construction. The system has a major advantage of being manufactured offsite over conventional tube foundation construction that requires casting of concrete on site.

TESTING

The EZ Tube system was tested to failure in a 300 Kip testing frame as shown in Figure 1. Figure 2 shows a close up of sections 1 through 5 and base A. The testing consisted of placing the loading head section, which was similar to the upper sections except it had a flat top to expedite uniform loading to the upper sections placed beneath it. Figure 3 shows the test setup for Test #1 (base B and upper sections 6 and 7). The base section was placed directly on the testing laboratory floor with the two upper sections on top. The loading head was placed on top of the last upper section then a hemispherical loading head with a load cell and steel shimming plate on top of it. The hydraulic ram loads the steel plate which transmits the load to the EZ Tube system. Loading Data were collected and stored on a computer as a function of time.

Test # 1

Test # 1 consisted of testing base B and Upper sections 6 and 7 as shown on Figure 3. The cast loading head was found to be weaker than the base and upper sections as shown in Figure 4. Upper section 7 significantly spalled during the testing. Some spalling was noted on upper section 6 as shown by the close up picture of Figure 5. The base section was cracked during the testing.



UNIVERSITY of NEW HAMPSHIRE

Test # 2

Sections base A and upper sections 1 and 2 were tested in Test # 2. Steel plates were used as a replacement for the broken cast loading head as shown in Figure 6. Figure 7 shows the failure of upper section 2 and spalling of upper section 1. Base section A cracked during the loading of test #2.

Test #3

Figure 8 shows the preexisting crack in base A and the test setup of sections 4 and 5. The failure of upper section 5 is shown in Figure 9. The crack in base A increased in size during the testing but did not cause the section to split apart as shown in Figure 10.

Results

The testing results are presented in Table 3. The weaker loading head influenced the total load carrying capacity of 102,000 pounds in Test #1. Test #2 and #3 with total load capacities of 146,000 and 156,000 pounds are more realistic of the true ultimate capacity of the EZ Tube system. The average ultimate load for Test #2 and #3 was 152,000 pounds. This translates to an approximate stress within the concrete of the upper section of 1,340 psi and a maximum soils foundation loading of 35 tons per square foot.

Summary and Conclusions

Based upon the testing of the EZ Tube system as delivered to the UNH testing laboratories the ultimate capacity is in excess of 150,000 pounds per unit. The load transmitted to a soil foundation is approximately 35 tons per square foot at the ultimate loading capacity.

Respectfully submitted,



Dr. David Gress, Ph.D., P.E.
Professor of Civil Engineering



UNIVERSITY of NEW HAMPSHIRE

Table 1 Test specimen identification and description

Test Specimens Identification	Description
Loading Head	12" diameter and approximately 9" high
Base A	20" diameter and approximately 9" high and 140 pounds
Base B	20" diameter and approximately 9" high and 140 pounds
Section 1	12" diameter and 12" high approximately 75 pounds
Section 2	12" diameter and 12" high approximately 75 pounds
Section 3	12" diameter and 12" high approximately 75 pounds
Section 4	12" diameter and 12" high approximately 75 pounds
Section 5	12" diameter and 12" high approximately 75 pounds
Section 6	12" diameter and 12" high approximately 75 pounds
Section 7	12" diameter and 12" high approximately 75 pounds

Table 2 Test sections testing order

Test	Components tested ^a
1	Base B with Sections 6, 7 and the Loading Head
2	Base A with Sections 1 and 2
3	Base A with Sections 4 and 5

Note: ^a Section 3 was not tested

Table 3 Laboratory testing data

Test	Failure Load	Loading Rate
1	102,400 lbs	2,200 lbs/sec
2	146,100 lbs	1,200 lbs/sec
3	157,900 lbs	1,000 lbs/sec